

isc Silicon NPN Power Transistor

2SC4622

DESCRIPTION

- High Collector-Emitter Sustaining Voltage-
: $V_{CEO(SUS)} = 400V(\text{Min})$
- High Switching Speed
- Low Collector Saturation Voltage
- High Reliability

APPLICATIONS

- Switching regulators
- Ultrasonic generators
- Solid state relay
- General purpose power amplifiers

ABSOLUTE MAXIMUM RATINGS($T_a=25^\circ\text{C}$)

SYMBOL	PARAMETER	VALUE	UNIT
V_{CBO}	Collector-Base Voltage	500	V
V_{CEO}	Collector-Emitter Voltage	400	V
V_{EBO}	Emitter-Base voltage	10	V
I_C	Collector Current-Continuous	7	A
I_B	Base Current-Continuous	2	A
P_C	Collector Power Dissipation @ $T_C=25^\circ\text{C}$	50	W
T_J	Junction Temperature	150	$^\circ\text{C}$
T_{stg}	Storage Temperature Range	-55~150	$^\circ\text{C}$

THERMAL CHARACTERISTICS

SYMBOL	PARAMETER	MAX	UNIT
R_{th-j-c}	Thermal Resistance, Junction to Case	2.5	$^\circ\text{C/W}$

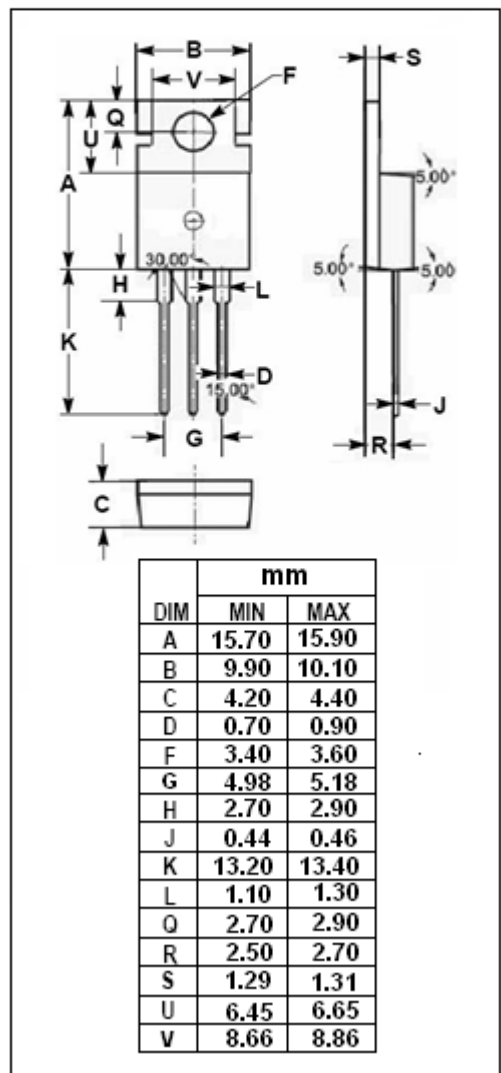
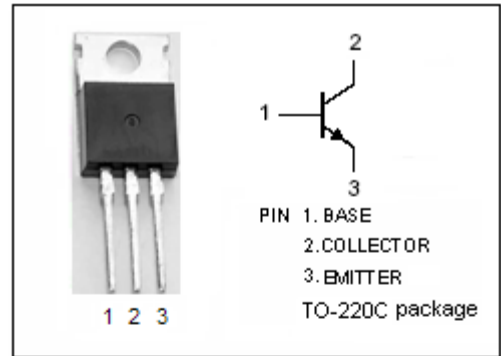

isc Silicon NPN Power Transistor

2SC4622

ELECTRICAL CHARACTERISTICS

 $T_C=25^{\circ}\text{C}$ unless otherwise specified

SYMBOL	PARAMETER	CONDITIONS	MIN	TYP.	MAX	UNIT
$V_{CEO(SUS)}$	Collector-Emitter Sustaining Voltage	$I_C=0.2\text{A}; I_B=0$	400			V
$V_{(BR)CBO}$	Collector-Base Breakdown Voltage	$I_C=1\text{mA}; I_E=0$	500			V
$V_{(BR)EBO}$	Emitter-Base Breakdown Voltage	$I_E=1\text{mA}; I_C=0$	10			V
$V_{CE(sat)}$	Collector-Emitter Saturation Voltage	$I_C=4\text{A}; I_B=0.8\text{A}$			0.8	V
$V_{BE(sat)}$	Base-Emitter Saturation Voltage	$I_C=4\text{A}; I_B=0.8\text{A}$			1.2	V
I_{CBO}	Collector Cutoff Current	$V_{CB}=450\text{V}; I_E=0$			0.1	mA
I_{EBO}	Emitter Cutoff Current	$V_{EB}=10\text{V}; I_C=0$			0.1	mA
h_{FE}	DC Current Gain	$I_C=4\text{A}; V_{CE}=5\text{V}$	10			

Switching times

t_{on}	Turn-on Time	$I_C=5\text{A}; I_{B1}=1\text{A}; I_{B2}=-2\text{A};$ $R_L=30\Omega; P_W=20\mu\text{s};$ Duty Cycle $\leq 2\%$			1.0	μs
t_{stg}	Storage Time				2.5	μs
t_f	Fall Time				0.5	μs